

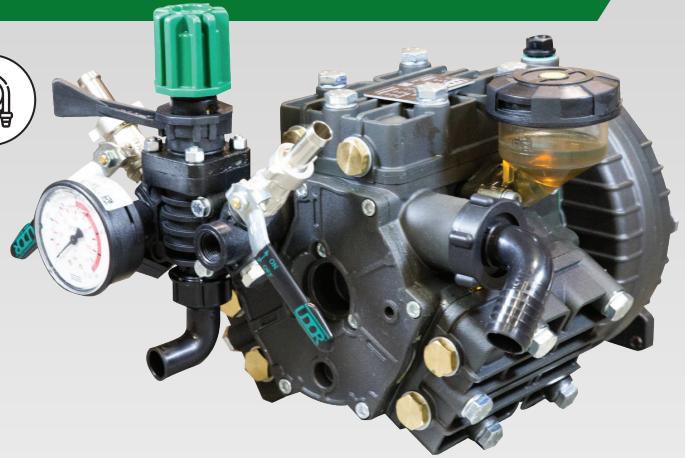

Scan this QR Code for more information



GREENTECH Diaphragms Standard. Buna-N Optional.

KAPPA 43 3-cylinder, medium pressure diaphragm pumps are internally manifolded with anodized aluminum construction and anodized aluminum and stainless steel liquid handling parts.

KAPPA 43 pumps are excellent choices for various horticultural, agricultural, lawn care, nursery, pest control and turf spraying applications. They are also effectively used for aircraft de-icing, hydrostatic testing and cleaning applications.

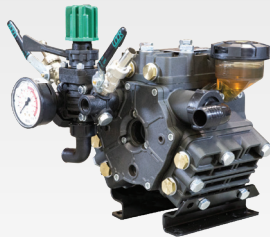

KAPPA 43

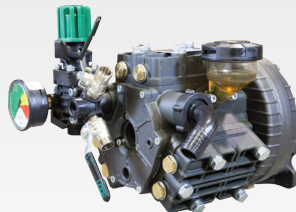

KAPPA 43 GR3/4LP

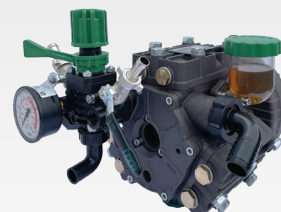

KAPPA 43 GR3/4

Model	GPM	l/min	PSI	bar	RPM	Drive Configuration	Weight
KAPPA 43	10.5	40.0	560	38	550	25 mm Solid Keyed Shaft. Mounting Rails	29 LBS
KAPPA 43 GR3/4LP	10.5	40.0	350	24	550	Gear Reduction for 3/4" Shaft Gas Engine, 4-6.5 HP	39 LBS
KAPPA 43 GR3/4	10.5	40.0	560	38	550	Gear Reduction for 3/4" Shaft Gas Engine, 4-6.5 HP	39 LBS

Specifications

KAPPA 43

Inlet Port	1" Hose Barb
Outlet Ports	(2) 1/2" Hose Barb
Bypass	3/4" Hose Barb
Piston Diameter	55mm
Crankshaft Stroke/Code	12.0mm / S
Dimensions	9.5"L x 11.5"W x 10.0"H

Lubrication: Requires 20 oz. of Udor Lube 40W Premium Pump Oil.
Alternate Oil: 30W non-detergent or 15W-40 non-detergent oil.

QUICK REFERENCE SERVICE PARTS

Description	Part #
Diaphragm Kit (GREENTECH)	8700.45
Diaphragm Bolt/Washer Kit	6062.48
Valve Kit	6062.46
Regulator Repair Kit	6062.A9
Complete Repair Kit	8700.45CK

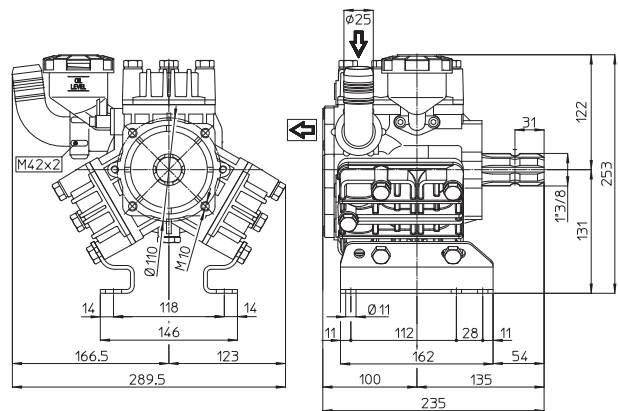

Dimensional Drawings are Shown in Millimeters.
To Convert to Inches, Multiply Dimension x 0.03937

Recommended Accessories and Drive Options



6010.93 / 6010.95
Control Unit
Regulator w/Gauge



5071.75
Gear Reduction
3/4" Shaft Gas Engine



0016.04
Venturi Agitator
1/2" MNPT Inlet



163.604.4
163.604.6
3/8" & 1/2" HB Elbow



UD1-16
1" HI-Flow Filter
16 Mesh Screen



15.5823
Udor Lube
Premium Pump Oil